

# BALANCED ZERO REGULATORS - ZERO GOVERNOR 500 °F

## BZR - 500 °F SERIES

### FEATURES

- Max. operating pressure: 350 mbar
- Max. differential pressure: 36 mbar
- Max. operating temperature: 260°C (500°F)
- Turndown range: 200:1
- Sensitivity: 0.1 mbar
- Accuracy: low flow:  $\pm 0.25$  mbar  
full flow:  $\pm 0.76$  mbar

### APPLICATIONS

- Gas regulation on venturi mixers.
- Gas regulation on proportional mixers.
- Gas regulation on supply lines of any kind.
- For use with high sulphur gases and other corrosive gases.

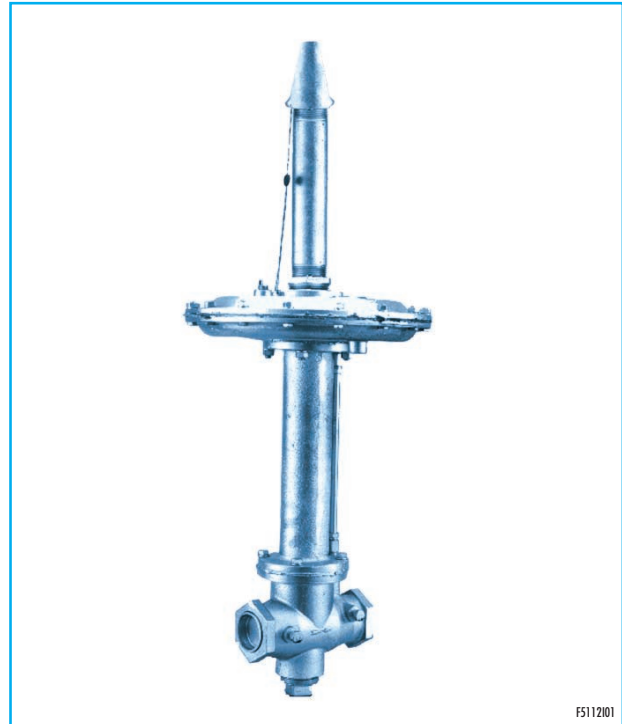

F5112101

### DESCRIPTION

Zero Regulators are meant to decrease fluid pressure to equal air pressure. They are double diaphragm Regulators. The first diaphragm, also called balancing diaphragm, is meant to divide the inlet gas chamber of the valve from the chamber under the main diaphragm; the second diaphragm balances out the outlet pressure of the lower chamber of the diaphragm itself and the pressure in the top chamber.

A compression spring loads the main diaphragm with an adjustable force which places the valve in an open position. When the outlet pressure under the main diaphragm equals the spring load, a balance of forces occurs to move the diaphragm and the valve assembly towards the closed position. The seal diaphragm is designed so that its area equals the effective area of the valve disc. Fluctuations in inlet pressure are thus counter-balanced by these two equal areas.

The upper diaphragm chamber is normally open to atmosphere while the lower diaphragm chamber, by means of the impulse connection, is subject to outlet pressure. With equal pressures in both chambers the valve stays closed; when there is an unbalance between the

pressures of the lower and upper chambers (positive pressure in the upper chamber due to the charge or negative in the lower chamber due to the suction of a Venturi mixer) the valve moves downward letting more gas flow into the system. As changes in flow are required by the connected system, there will be slight changes in the outlet pressure and a minor unbalance in forces on the main diaphragm. This large sensitive diaphragm will move either up or down, as required to restore the force balance.

The flow across the patented compensator produces a velocity condition which is proportional to flow. The impulse when combined with the outlet pressure is transmitted to the lower diaphragm chamber and automatically adjusts the valve to hold a constant delivery pressure.

The patented regulator assures highest accuracy over flow range. With no friction between sensitively counterbalanced parts, fast, positive response is assured. The BZR regulators guarantee dependable, precise gas flow control on all types of combustion systems.



**Headquarters**  
Esa S.r.l.  
Via E. Fermi 40 I-24035 Curno (BG) - Italy  
Tel. +39.035.6227411 - Fax +39.035.6227499  
esa@esacombustion.it - www.esapyronics.com

**International Sales**  
Pyronics International S.A./N.V.  
Zoning Ind., 4ème rue B-6040 Jumet - Belgium  
Tel +32.71.256970 - Fax +32.71.256979  
marketing@pyronics.be

## INSTALLATION

All BZR regulators are tested, set and sealed when shipped. If adjustment or repair is necessary, the regulator should be returned to the factory.

Regulators must always be mounted in a stem-up position, in a horizontal line. Any other mounting position will cause a malfunction. The arrow cast on the side of the valve body indicates direction flow.

Regulators should not be installed in areas where operating temperatures will exceed the maximum operating value.

One Zero Regulator may supply more than one burner, provided that some conditions are respected:

1. locate a valve between the BZR and every burner;
2. respect the maximum limit capacities of the BZR;
3. all the mixers connected to one single regulator must be in the same control area.

## CAPACITY TABLE

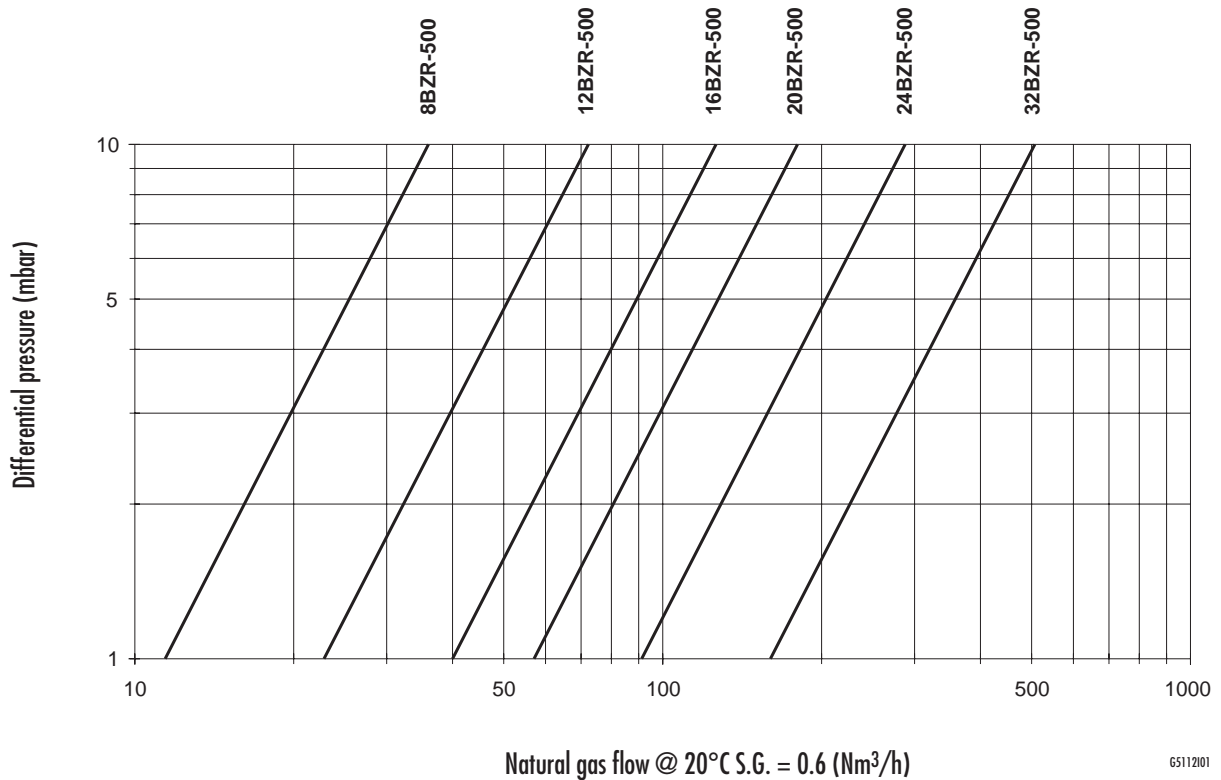

Natural gas flow @ 20°C S.G. = 0.6 (Nm<sup>3</sup>/h)

65112/01

## CORRECTION FACTOR TABLE

Gas temperature °C	93	121	149	176	204	232	260
Capacity multiplier	1.12	1.16	1.20	1.24	1.27	1.31	1.35

## DIMENSIONS

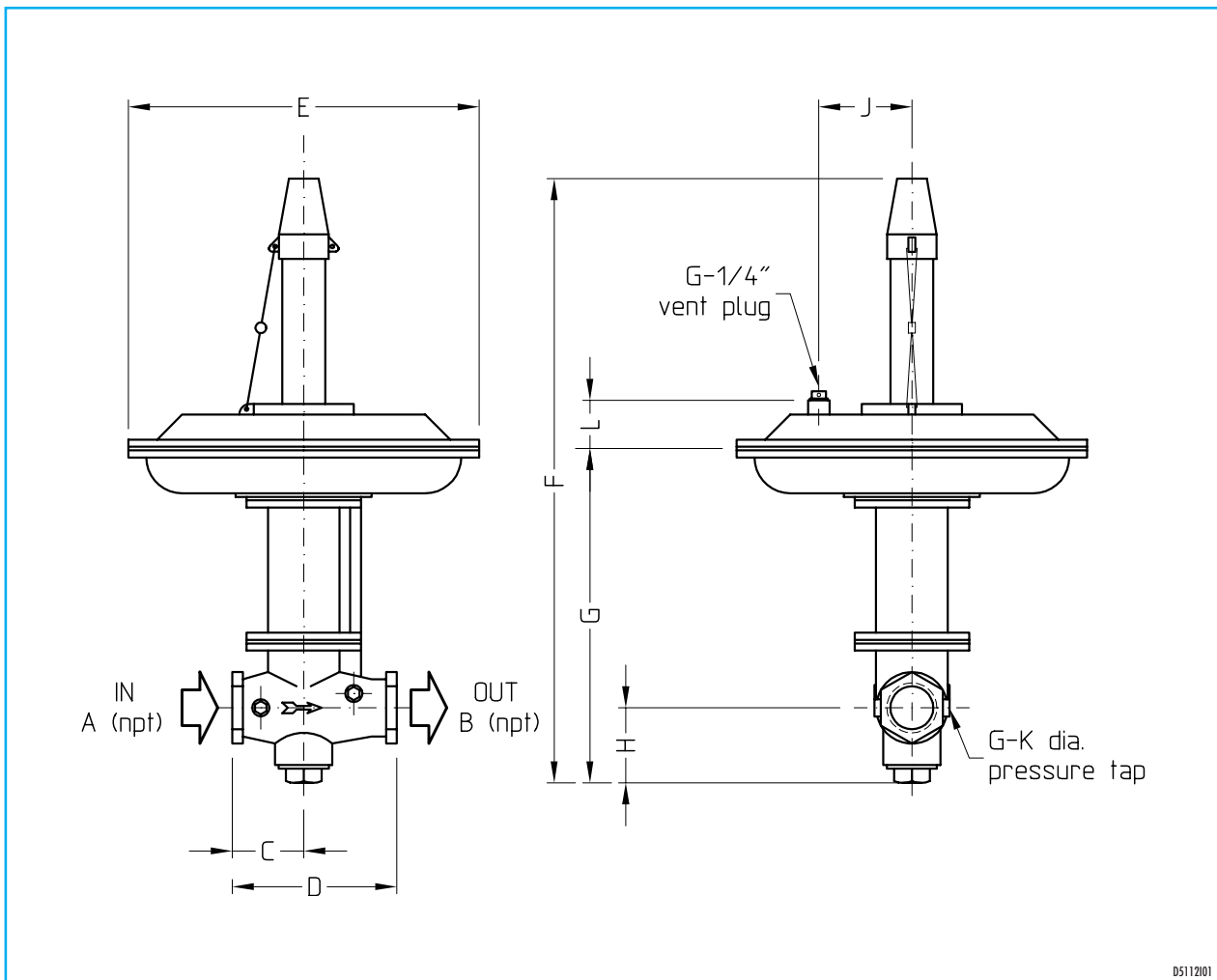

Catalog no.	In	Out	C mm	D mm	E mm	F mm	G mm	H mm	J mm	K	L mm	Weight kg
8 BZR - 260	NPT - 1"	NPT - 1"	60	120	248	584	403	51	86	1/8"	32	5.5
12 BZR - 260	NPT - 1.1/2"	NPT - 1.1/2"	76	165	298	797	467	82	98	1/4"	32	11.6
20 BZR - 260	NPT - 2.1/2"	NPT - 2.1/2"	101	216	355	880	536	89	92	1/4"	48	30
24 BZR - 260	NPT - 3"	NPT - 3"	146	292	355	921	578	111	92	1/4"	48	35
32 BZR - 260	NPT - 4"	NPT - 4"	162	473	610	1606	914	216	254	1/4"	64	111

**Note:**

Model 32BZR-500 is A.S.A. 150 flanged.